

19. Representing 3-D in 2-D

EXERCISE 19

Question 1.

If a polyhedron has 8 faces and 8 vertices, find the number of edges in it.

Solution:

Faces = 8

Vertices = 8

using Eulers formula,

$$F + V - E = 2$$

$$8 + 8 - E = 2$$

$$-E = 2 - 16$$

$$E = 14$$

Question 2.

If a polyhedron has 10 vertices and 7 faces, find the number of edges in it.

Solution:

Vertices = 10

Faces = 7

Using Eulers formula,

$$F + V - E = 2$$

$$7 + 10 - E = 2$$

$$-E = -15$$

$$E = 15$$

Question 3.

State, the number of faces, number of vertices and number of edges of:

(i) a pentagonal pyramid

(ii) a hexagonal prism

Solution:

(i) A pentagonal pyramid

Number of faces = 6

Number of vertices = 6

Number of edges = 10

(ii) A hexagonal prism

Number of faces = 8

Number of vertices = 12

Number of edges = 18

Question 4.

Verify Euler's formula for the following three dimensional figures:

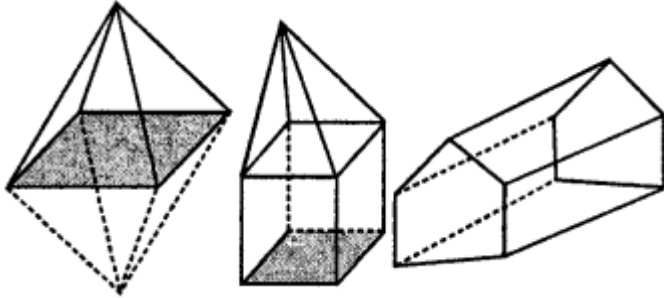

Solution:

(i) Number of vertices = 6

Number of faces = 8

Number of edges = 12

Using Euler formula,

$$F + V - E = 2$$

$$8 + 6 - 12 = 2$$

$$2 = 2 \text{ Hence proved.}$$

(ii) Number of vertices = 9

Number of faces = 8

Number of edges = 15

Using, Euler's formula,

$$F + V - E = 2$$

$$9 + 8 - 15 = 2$$

$$2 = 2 \text{ Hence proved.}$$

(iii) Number of vertices = 9

Number of faces = 5

Number of edges = 12

Using, Euler's formula,

$$F + V - E = 2$$

$$9 + 5 - 12 = 2$$

$$2 = 2 \text{ Hence proved.}$$

Question 5.

Can a polyhedron have 8 faces, 26 edges and 16 vertices?

Solution:

Number of faces = 8

Number of vertices = 16

Number of edges = 26

Using Euler's formula

$$F + V - E$$

$$\Rightarrow 8 + 16 - 26 \neq -2$$

$$\Rightarrow -2 \neq 2$$

No, a polyhedron cannot have 8 faces, 26 edges and 16 vertices.

Question 6.

Can a polyhedron have:

- (i) 3 triangles only ?
- (ii) 4 triangles only ?
- (iii) a square and four triangles ?

Solution:

- (i) No.
- (ii) Yes.
- (iii) Yes.

Question 7.

Using Euler's formula, find the values of x, y, z.

	Faces	Vertices	Edges
(i)	x	15	20
(ii)	6	y	8
(iii)	14	26	z

Solution:

$$(i) F + V - E = 2$$

$$\Rightarrow x + 15 - 20 = 2$$

$$\Rightarrow x - 5 = 2 \Rightarrow x = 2 + 5 = 7$$

$$(ii) F + V - E = 2$$

$$\Rightarrow 6 + y - 8 = 2$$

$$\Rightarrow y - 2 = 2$$

$$\Rightarrow y = 2 + 2 \Rightarrow y = 4$$

$$(iii) F + V - E = 2$$

$$\Rightarrow 14 + 26 - Z = 2$$

$$\Rightarrow -Z = 2 - 40 \Rightarrow Z = 38$$

Question 8.

What is the least number of planes that can enclose a solid? What is the name of the solid.

Solution:

The least number of planes that can enclose a solid is 4.

The name of the solid is Tetrahedron.

Question 9.

Is a square prism same as a cube?

Solution:

Yes, a square prism is same as a cube.

Question 10.

A cubical box is 6 cm x 4 cm x 2 cm. Draw two different nets of it.

Solution:

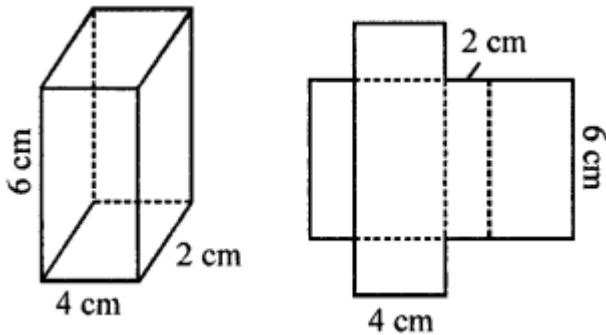

Question 11.

Dice are cubes where the sum of the numbers on the opposite faces is 7. Find the missing numbers a, b and c.

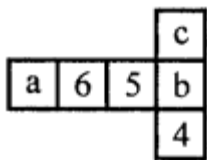

Solution:

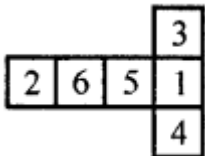

Question 12.

Name the polyhedron that can be made by folding each of the following nets:

(i)

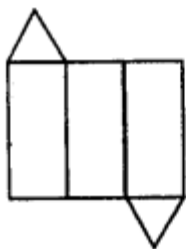

(ii)

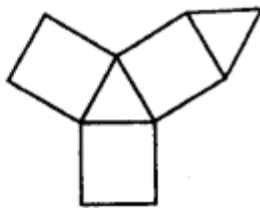

(iii)



Solution:

- (i) Triangular prism. It has 3 rectangles and 2 triangles.
- (ii) Triangular prism. It has 3 rectangles and 2 triangles.
- (iii) Hexagonal pyramid as it has a hexagonal base and 6 triangles.

Question 13.

Draw nets for the following polyhedrons:

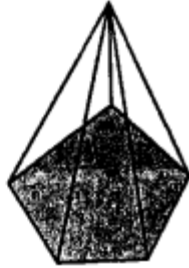
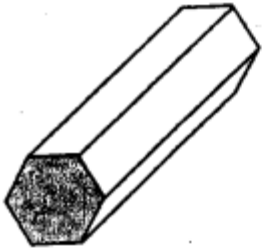

Solution:

Net of hexagonal prism:

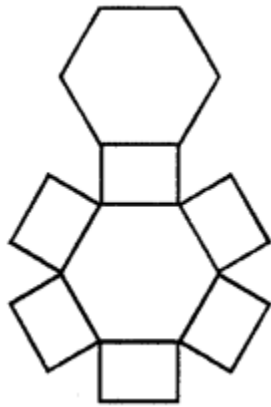

Net of pentagonal pyramid:

